

## Applications

For long length lines and heavy-duty installations. It is used for switching lines into double line lubrication systems of grease or oil.

## Features

- ▶ Two or three positions selectable
- ▶ High performances
- ▶ Steel body EN 10087-11SMnPb30 and electroplated coating of zinc according to ISO 2081 – Fe/Zn12/A.
- ▶ Operation for both grease or oil
- ▶ Available in several tensions



## Description

The electromagnetic reverser is piston driven and its function is to change the direction of the flow in oil or grease circuits in double line systems, the manoeuvre is carried out by means of two coils.

### Design and operating principle

The directional valves consist essentially of a body (1), one or two solenoid coils (2), the piston (3), and one or two return springs (4).

In the depressurization state, the piston (3) is kept in the central or rest position by the return springs (4). The piston (3) is operated by means of the solenoid (2). The magnetic force of the solenoid (2) acts through a pusher (5) on the piston (3) moving it from its resting position to the desired final position. In this way the desired flow directions are free, depending on the type of piston used. Once the solenoid (2) is depressurized, the piston (3) is moved again by the return spring (4) to its resting position.

The design of the arrangement of the connections follows the Cetop industrial standard that is given by flow capacity, therefore they must always be mounted on a secondary base of Nortek ref. 2012555.F10.

Note: To ensure proper operation, the solenoid pressure chamber must always be filled with oil.

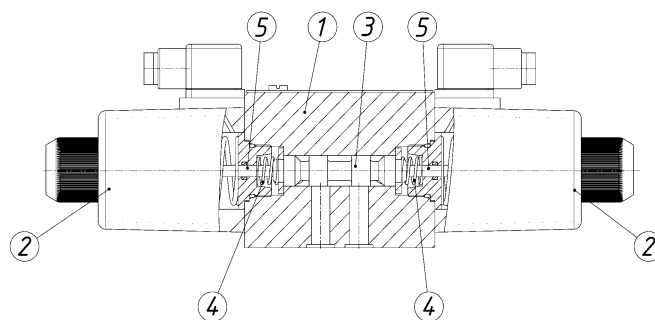

Operating principle illustration

## Installation

It must be connected to a control panel and the reversion must be made through a final line pressure switch.

The mounting system is stackable and allows multiple circuits to be made, minimizing the necessary space, saving assembly time and expensive pipe installations.

## Specifications

<b>Flow</b>	70 kg/h
<b>Maximum working pressure</b>	350 kg/cm <sup>2</sup>
<b>Operating temperature</b>	-20 °C / +80 °C
<b>Connections</b>	According to Cetop C5 standar
<b>Nortek base inlet connections</b>	G 3/4
<b>Nortek base outlet connections</b>	G 1/2
<b>Electrovalve power</b>	AC 8 W DC 9 W
<b>Weight</b>	6,2 kg

## Dimensional drawing

Dimensions in mm.

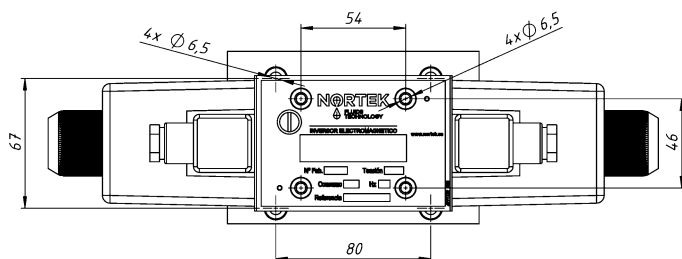
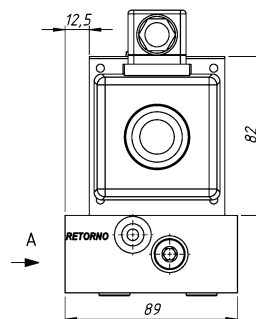
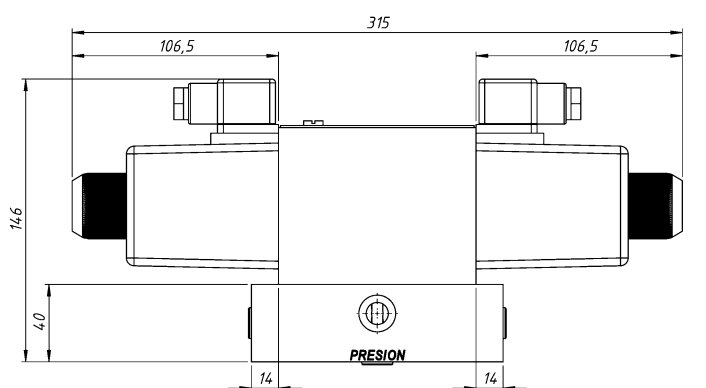

VISTA A

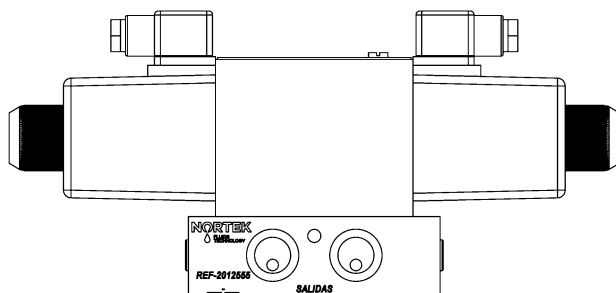

MODEL	SYNOPTIC
A	
B	
C	
D	

## Ordering information

ADD CODE DEPENDING ON ASSEMBLY

	<b>CE70-</b>	<b>X</b>	<b>X</b>	<b>-XX</b>
<b>Model (See table pag. 2)</b>				
A: 4-way 3-position, closed center		<b>A</b>		
B: 4-way 3-position, open center		<b>B</b>		
C: 4-way 2-position		<b>C</b>		
D: 4-way 3 positions, center open to return		<b>D</b>		
<b>Voltage</b>				
110 V 50 Hz			<b>5</b>	
220 V 50 Hz			<b>6</b>	
115 V 60 Hz			<b>7</b>	
255 V 60 Hz			<b>8</b>	
24 V d.c			<b>9</b>	
<b>Special code</b>				
For non-standard elements				<b>-XX</b>