

## Applications

These pumps are designed to work with grease and oil, whatever environment, as long as there is compressed, these pumps are used in installations with any type of flow.

## Features

- ▶ Compact
- ▶ Low air consumption
- ▶ For grease and oil
- ▶ Built-on safety valve
- ▶ Control speed by means of PLC



## Description

High pressure pneumatic pump with pneumatic actuation by means of a 4-way solenoid valve, 2 positions, adjustable capacity according to the lubrication points.

It is complemented with Nortek tanks of 5, 10 kg (3 and 20 kg on request) to be chosen by the client according to their needs.

## Design and operating principle

Operation is similar to most of the double action piston pumps. The pump is pneumatically operated by the solenoid valve and stops completely only in the upward stroke, performs the down stroke due to the change of the solenoid valve.

The air pressure is exerted simultaneously by the solenoid valve through the inlet and relief holes A and B, this causes the movement of the piston as shown in "Figure 1" and effects the greasing by the outlet C.

Fig.1: Illustration of operating principle

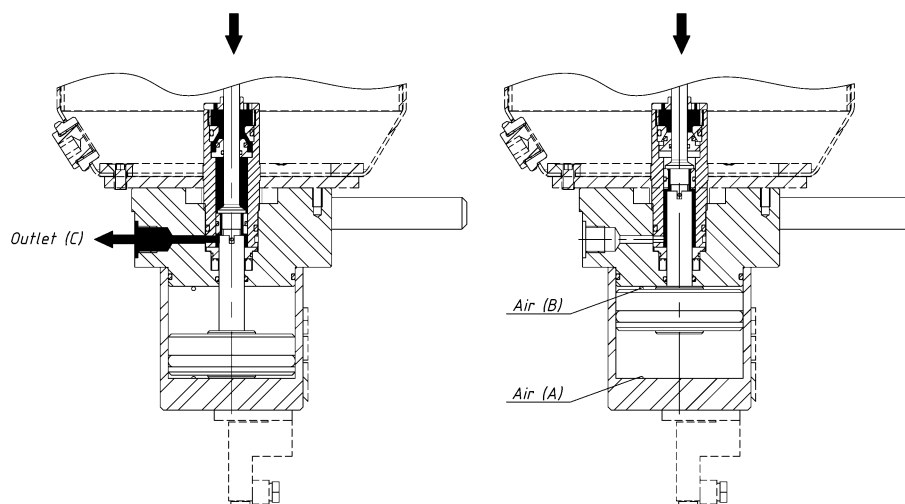

## Installation

The installation is carried out with an electrical panel designed by Nortek type 2058914N-S\_AL, from here the basic functions are regulated such as machine downtime or lubrication time, besides having the possibility of regulating the speed, its cycle regulation by Standard stroke is 1 s (1 s Greasing / 1 s Stop).

## Specifications

<b>Ratio</b>	45 : 1
<b>Maximum working pressure</b>	300 bar
<b>Recommended air pressure</b>	< 9 bar
<b>Recommended maximum speed</b>	1 cycle/second
<b>Air inlet</b>	G 1/8
<b>Grease outlet</b>	G 3/8
<b>Flow</b>	4 cm <sup>3</sup>
<b>Approximate weight</b>	4,5 kg

## Dimensional drawing

Dimensions in mm

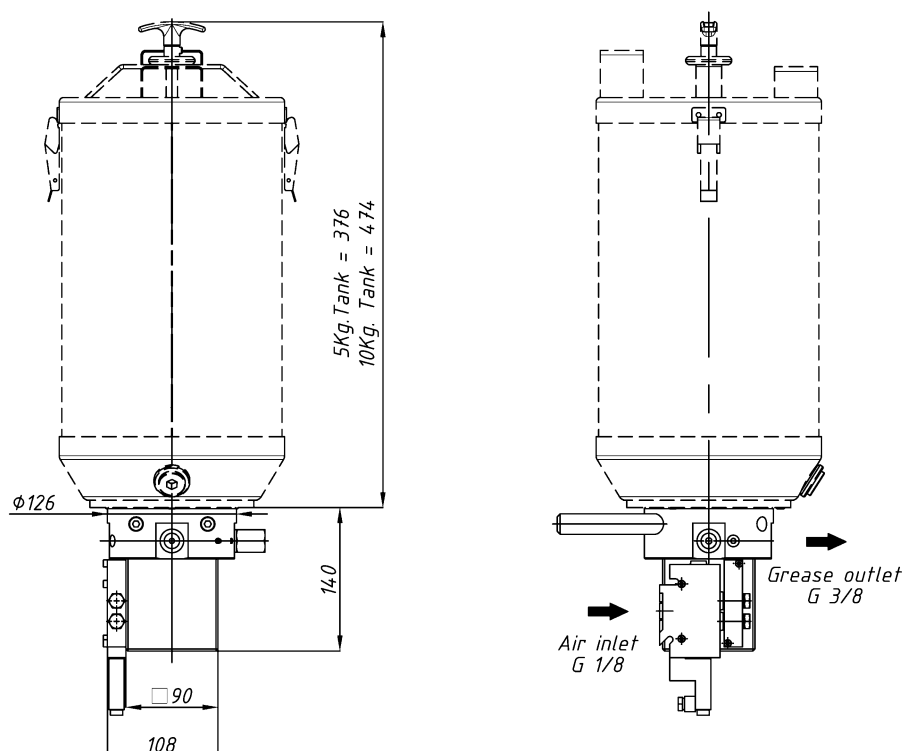

## Ordering information

Specifications	Reference
Pneumatic pump	1038500.000

Il est toujours nécessaire de définir le modèle de dépôt requis :

Specifications	Reference
Tank 5 kg	4102105.000
Tank 10 kg	4111110.000

## Accessories

Specifications	Reference
Tank adaptor flange 10 kg	4300159.F12
Solenoid valve 5 ways 2 positions 24 V	2032120.000

## ADD CODE DEPENDING ON ASSEMBLY

	<b>BNP45-</b>	<b>X</b>	<b>XX</b>	<b>-XX</b>
<b>Lubricant</b>				
Oil		<b>A</b>		
Grease		<b>G</b>		
<b>Tank</b>				
Tank 5 kg			<b>05</b>	
Tank 10 kg			<b>10</b>	
<b>Special code</b>				
For non-standard elements				<b>-XX</b>